

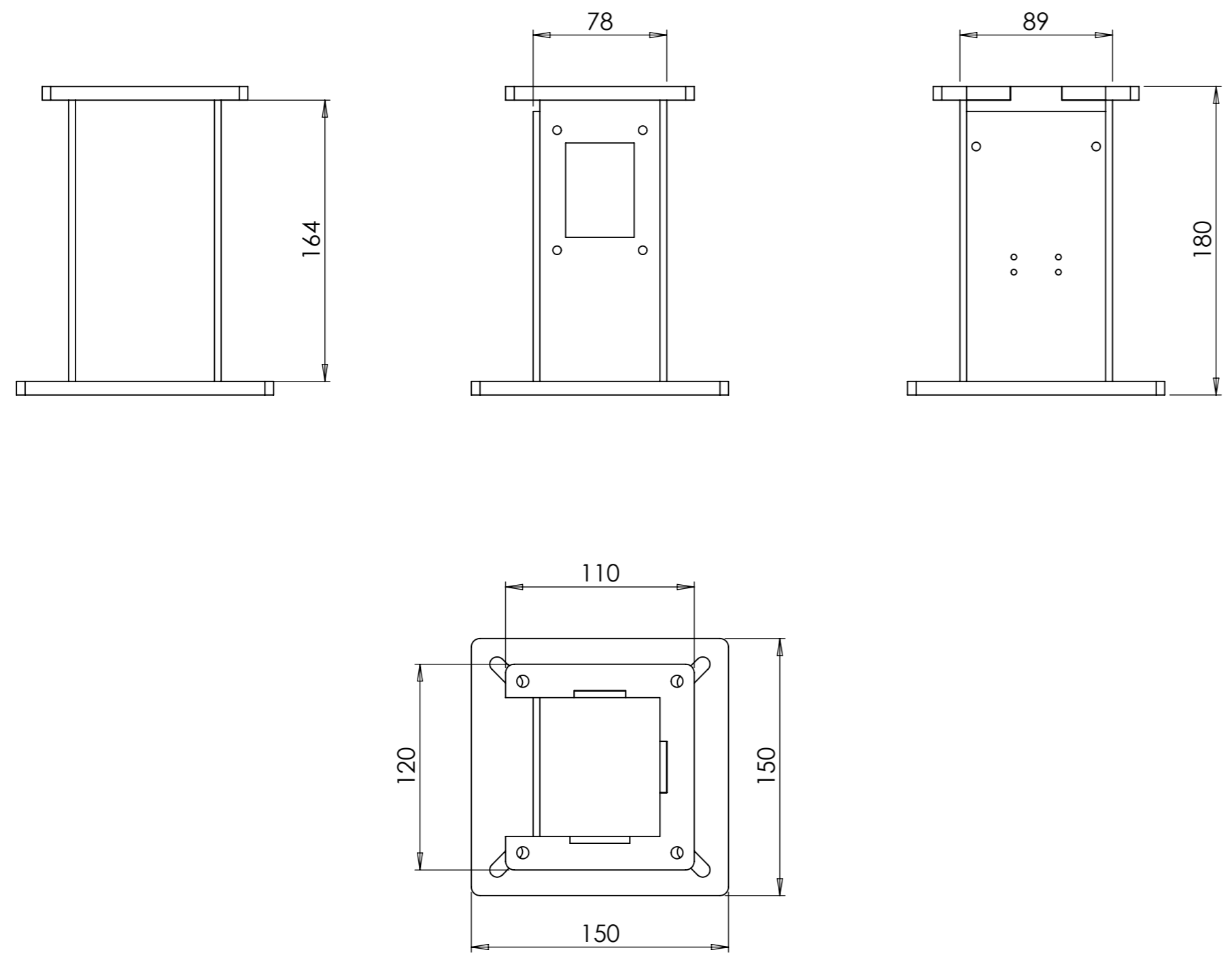

ITEM NO.	NUMBER	TITLE	QTY.
1	2200	Base Flange 2200	1
2	2263	Side Wall 2263	1
3	2264	Side Wall 2264	1
4	2265	Side Wall 2265	1
5	2266	Side Wall 2266	1
6	2268	Top Flange 2268	1

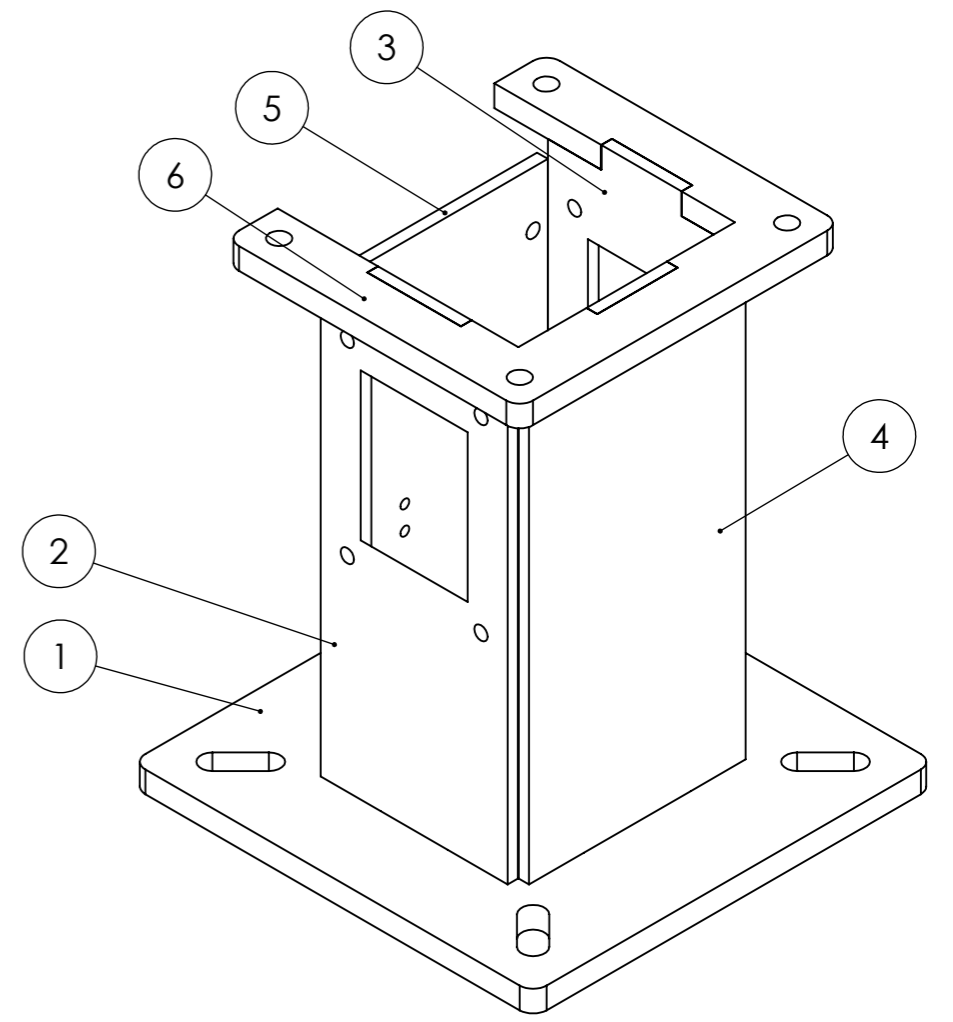

TO BE CONTINUOUSLY WELDED ON OUTSIDE



TITLE: Type 1 Neck 2468		REVISION
		TSM Controls Ltd The Demesne, Dundalk, Co.Louth, Ireland Tel: +353 42 9335560 Fax: +353 42 9334422 Email: info@tsm-controls.com Web: www.tsm-controls.com
MATERIAL:	NAME: sbrady	UNLESS OTHERWISE SPECIFIED: DIMENSIONS ARE IN MILLIMETERS TOLERANCES: ISO 2768-1 m IF IN DOUBT ASK
FINISH:	PRT/ASM NO. 2468	
DEBUR AND BREAK SHARP EDGES	DATE: 26/11/2012	SCALE:1:3 SHEET 1 OF 1
WEIGHT:		A3